YACHT YARD FRAM



MULE WORKBOAT





MULE WORKBOAT – Technical data

Lenght over all	7.62m
Lenght on waterline	7.34m
Beam	2.70m
Draft	1.1m
Engine	220 hp
Fuel tank	2 x 300 l
Water tank	60 l
Grey water tank	60 l
Black water tank	60 l
Hull	steel
Superstructure	Steel/optional aluminium

MULE WORKBOAT

Equipment specification

Hull and superstructure

Hull made of welded steel plates. Boat design certified by PRS
Vessel desgned under CE guidelines.

WC

Ceramic sink with hot and cold running water
Manual marine toilet

Work Deck

Work deck covered with antislip material
Engine acces hatch
Hydraulic operated aft flap

Hull equipment

Superstructure windows by Gebo_____ 8 pcs
Wheelhouse ventilators in stainless casing_____ 2 pcs
Stainless steel railing
Handrelingi on superstructure
Anodes_____ 15 pcs

Mooring

Electric anchor winch by Maxwell_____ 1 pcs
Lewmar Delta anchor 63 kg_____ 1 pcs
Anchor chain 14 mm, 65 m_____ 1 pcs
Stainless bolards_____ .4 pcs

Painting

Hull sandblasted
Hull and superstructure secured by complex paint system
Paint system by Teknos - Oliva
Antifouling in standard

Engine

IVECO S30 ENT o mocy 230 HP
Wet exhaust by Vetus
Stainless steel propulsion shaft
4 blade propeler

Seering system

Hydraulic steering system by Kobelt

Drainage

Electric blige pump by Jabsco- 2 pcs
Auxiliary manual bilge pump

Lights

Navigation lamps by Aquasignal

Heating and air conditioning

Optional air conditioning, Diesel heating in wheelhouse by
Webasto

Tanks

All tanks are stainless steel with indicators, valves, filling system
and ventilation.

Electric instalation

Generator IS 11.5T 13 kVA 50Hz
Generator exhaust by Vetus
Electric instalation 24 V DC
Bow thruster batteries- 225 Ah
Main battery serviceless gel 24 V- 800 Ah

Electronics

Raymarine i50 Speed, i50 Depth, i50 Wind
Kompas w kokpicie
GPS Raymarine Raystar 125
VHF Raymarine Ray 240













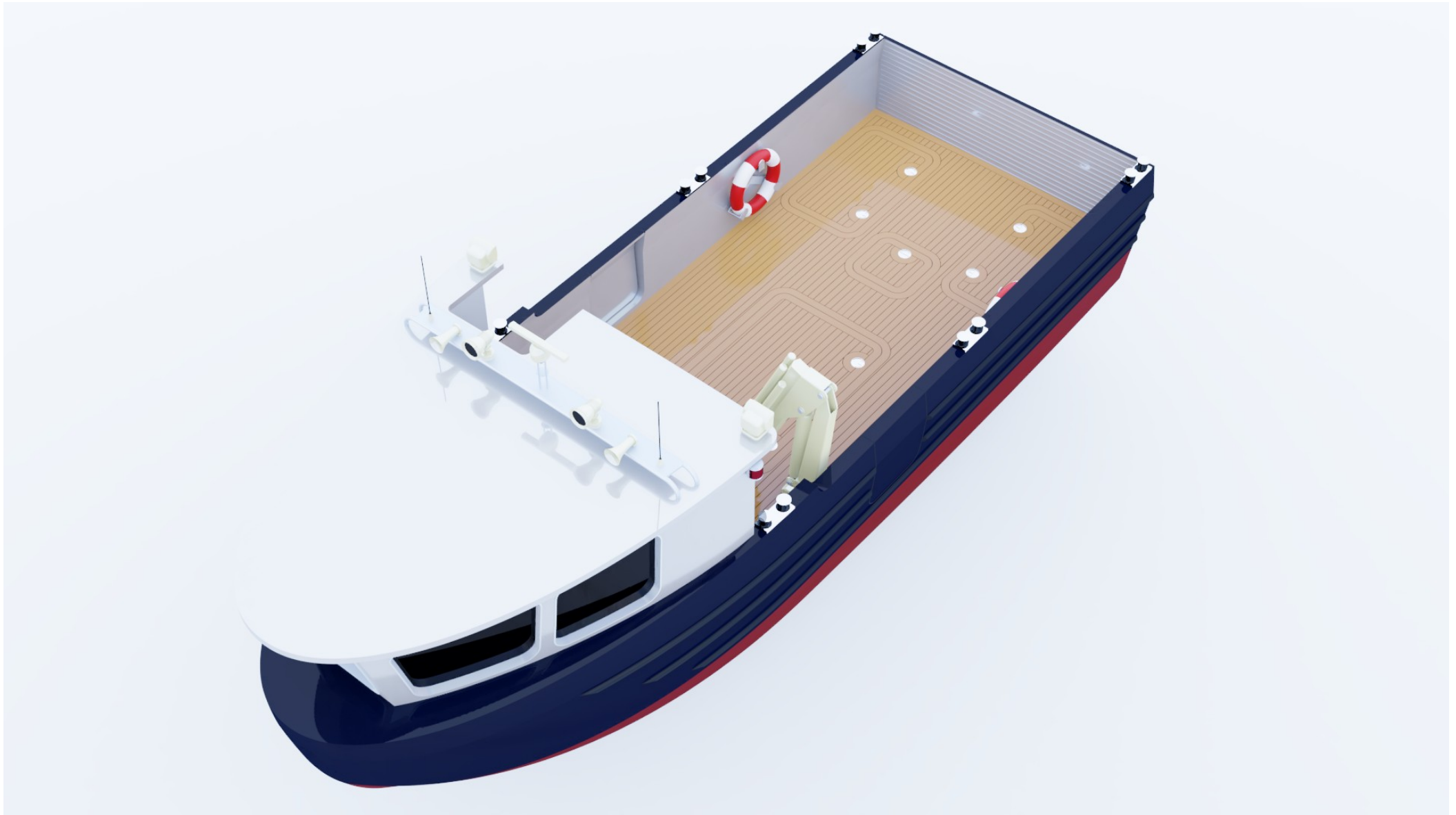



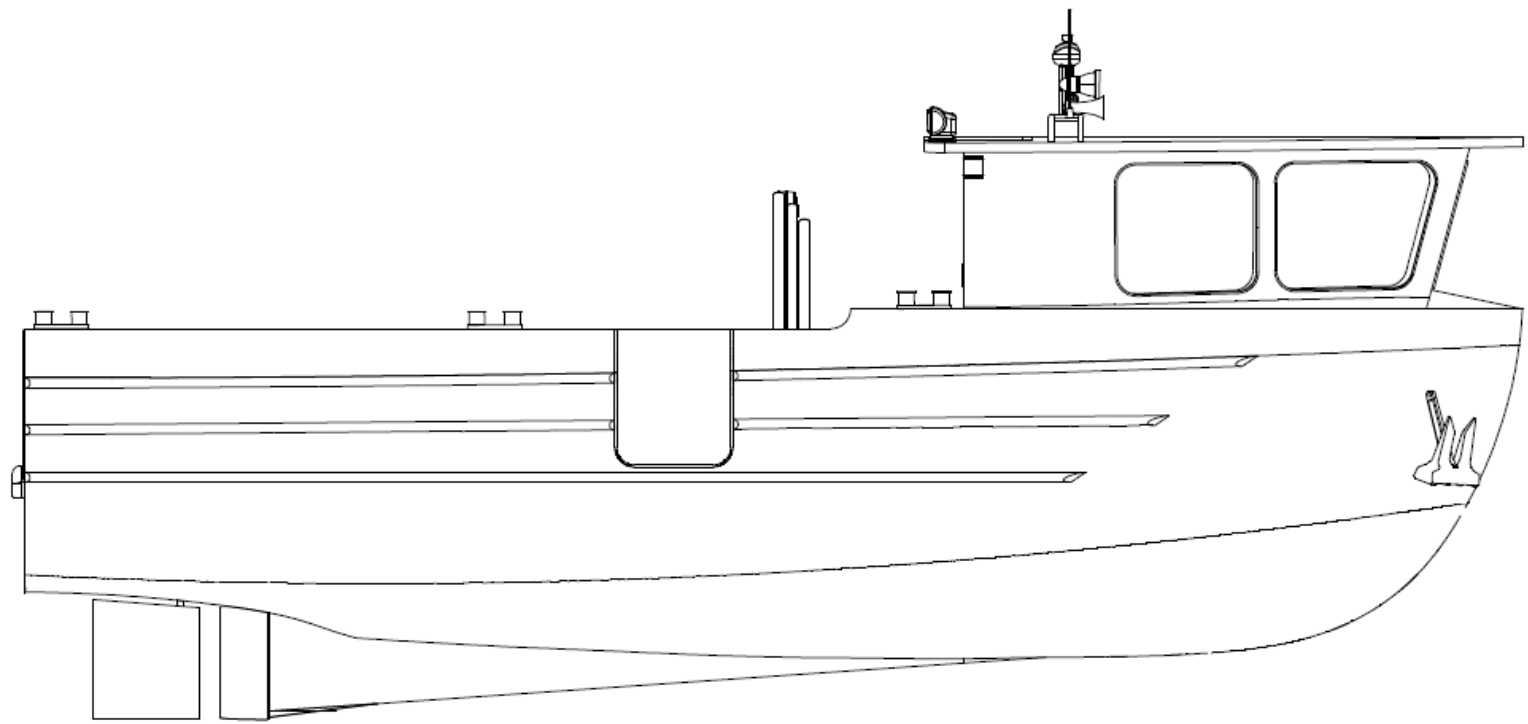

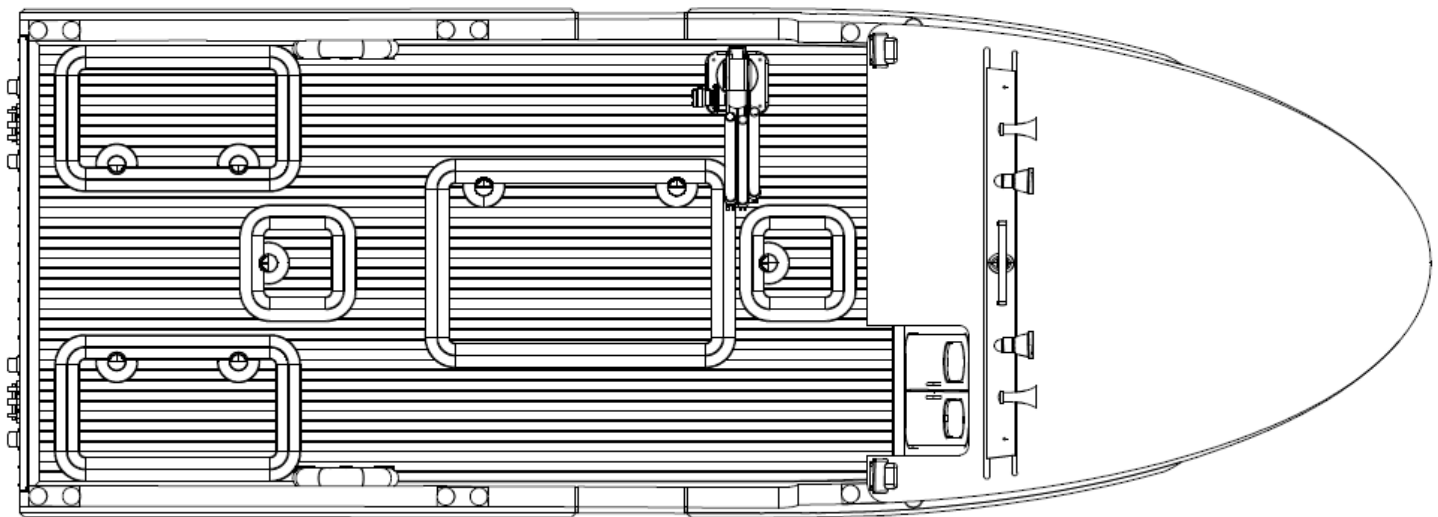

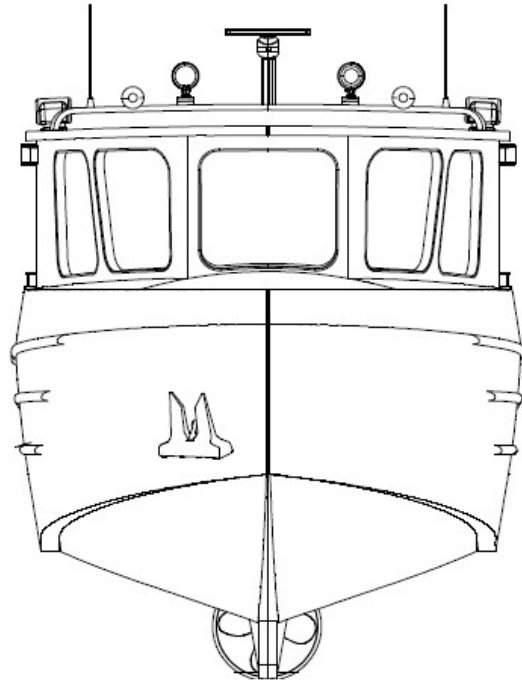

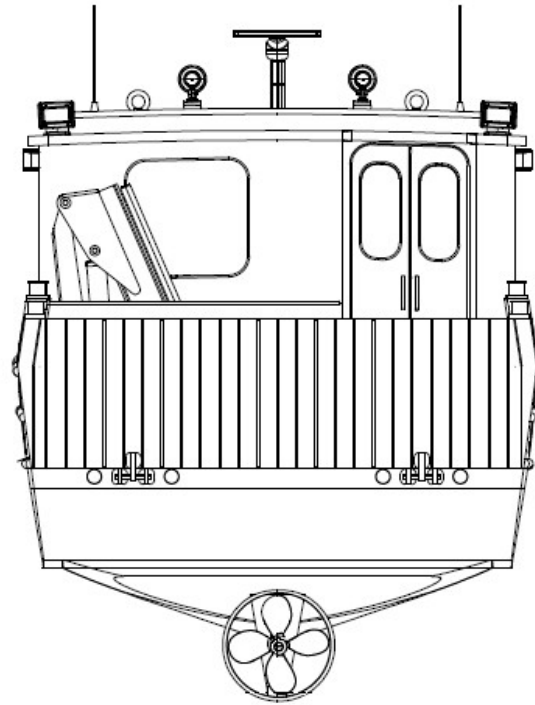

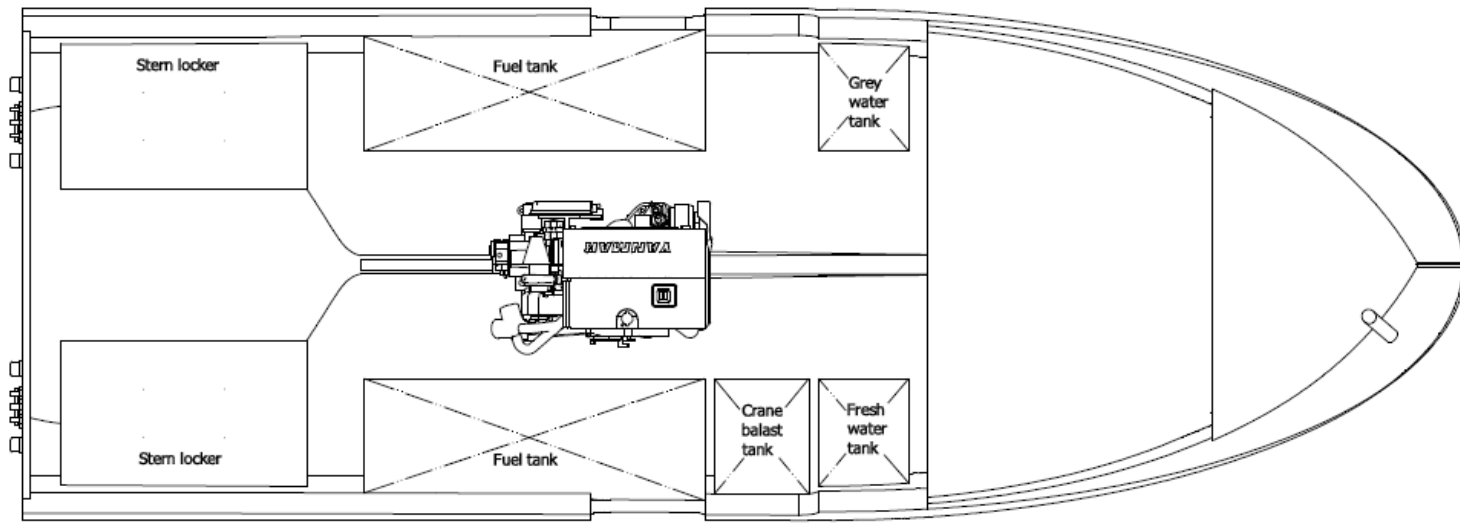

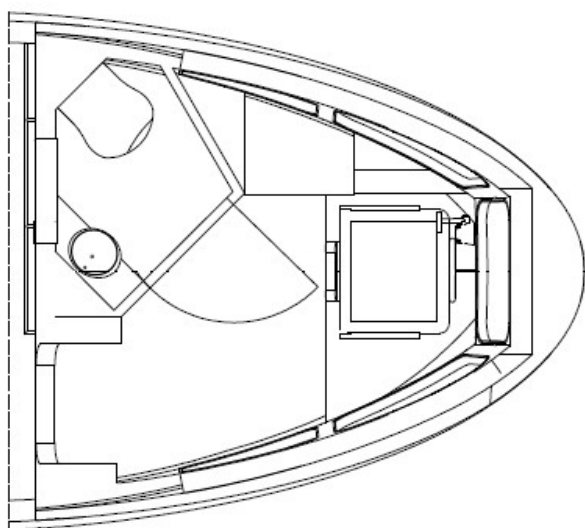



YACHT YARD FRAM

Address: Obrzycka 43 st
64-600 Oborniki Poland

Email: fram-marketing@o2.pl

Www.stoczniafram.pl

Tel +48 61 29 61 753

Mobile: +48 513 843 802 pol.

Mobile: +48 508 213 349 eng.
